

Case Study

The stainless steel solar façade
of a highway maintenance building
at Bursins, Switzerland



Stainless Steel in Solar Energy



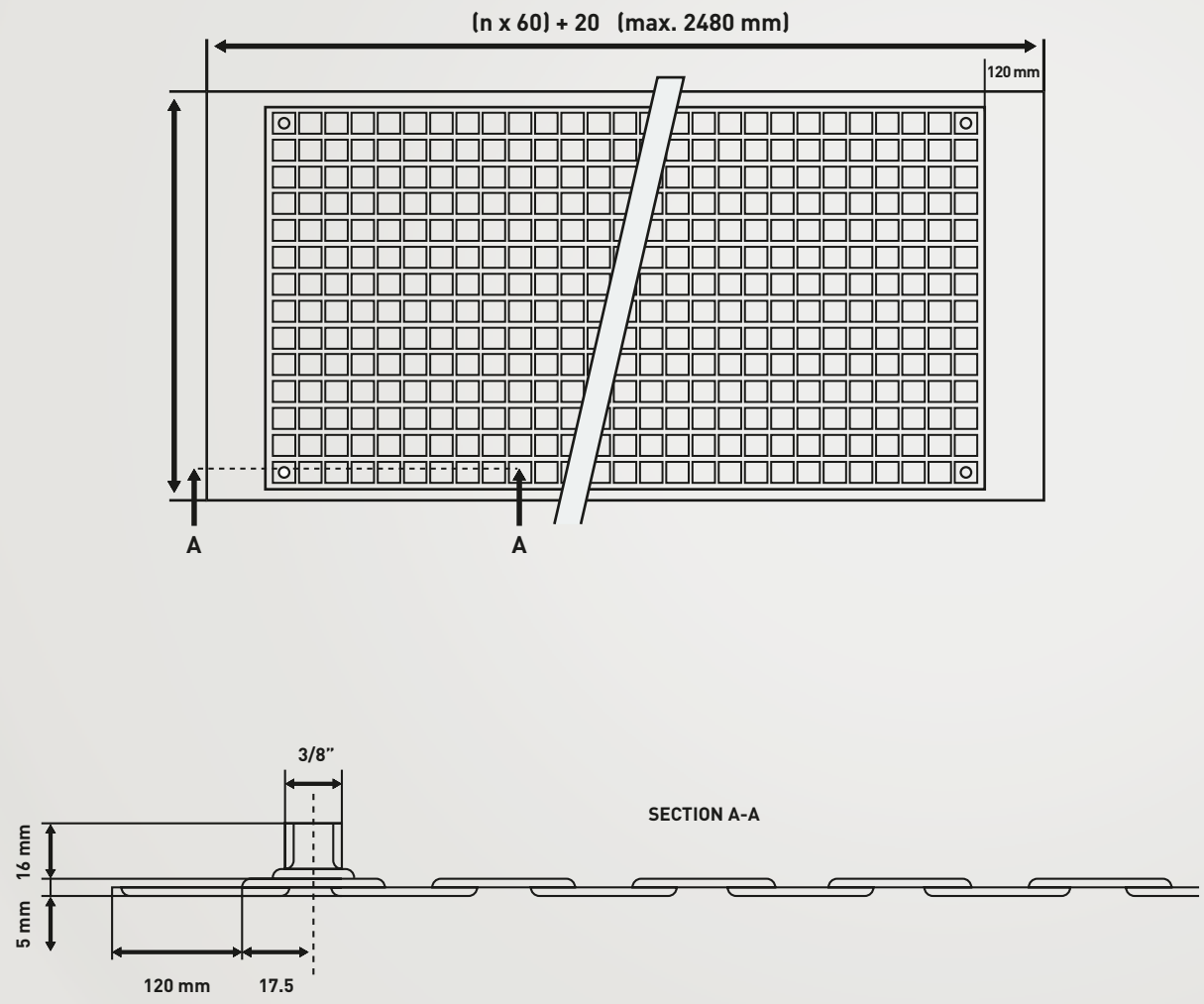

FIGURE 1: The principle of stainless steel cushion panels: two patterned, black-chromed stainless steel sheets are assembled back to back. The peaks and troughs are shifted against each other so the fluid can flow through the resulting voids. In contrast to conventional panels, the fluid is in contact with nearly the full surface of the absorber sheet. This principle makes the heat transfer particularly efficient.

Project Concept

The Centre d'entretien des Routes Nationales (CeRN) highway maintenance building was developed as a replacement for an existing maintenance building on the same site. The client, État de Vaud, organised an architectural competition for the design of the new building. For the first time in western Switzerland, clear sustainability demands were outlined in an architectural competition. The client demanded that the ecological, energy and economic aspects of sustainability should be considered in the design of the building.

The site of the building is part of the Swiss natural landscape inventory as it sits amidst the vineyards of "la Côte" near Geneva. The winning architect, Atelier niv-o, proposed a solution that integrated the new building into the vineyard setting through its dimensions, orientation and openings.

Materials were chosen to reduce the environmental impact of the building both during construction and use. Minimisation of transport and grey energy were stringent demands. Heat losses had to be reduced sharply and compensated for by passive and active solar gains. The remaining heat demand had to be covered by burning wood provided from regular highway maintenance. Maximising the use of daylight, controlled ventilation and the use of lake water were incorporated into the design to improve the building's performance.

The economy of the building was calculated over a period of 40 years and included the total costs for both installation and operation over its lifespan. The total cost works out cheaper than that of buildings comparable in size and function.



FIGURE 2: Model of the new maintenance building

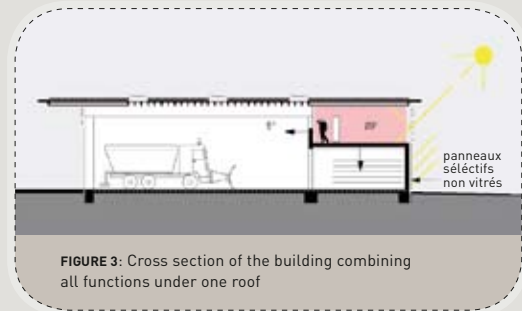

FIGURE 3: Cross section of the building combining all functions under one roof

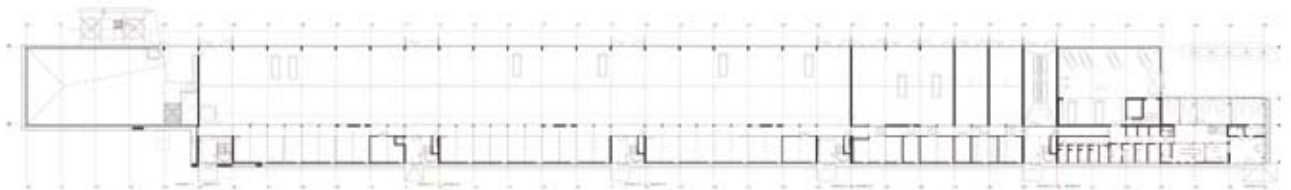

FIGURE 4: Ground floor layout of the new maintenance building



FIGURE 5: South facade with unglazed stainless steel solar collectors for floor heating and hot water. The connections between the absorber elements and the distribution pipes for the heat-transfer fluid are visible.

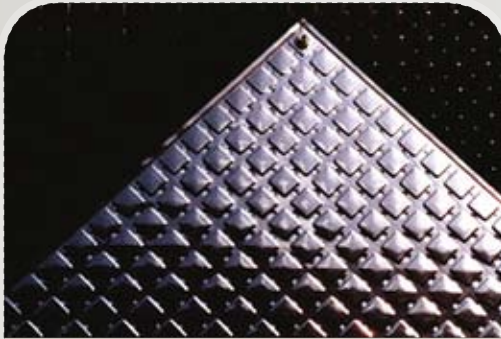

FIGURE 6: Geometry of the stainless steel absorber with selective coating for superior performance. Entrance or outlet for the heat transfer fluid is visible at the upper edge.



FIGURE 7: Close-up of the selective coated surface of the collector panels

Facade Concept

The south-facing facade of the building is covered with thermal solar collectors. The vertical position of the collectors provides a good compromise between solar gains and architectural integration. The result gives an optimum yield during the cooler months of the year when heating is required. The collectors produce maximum energy in the winter season which is used to heat the floor of the building. During summer the system still produces enough energy for the hot water needs of the building. By using the facade element, the building owner openly demonstrates their commitment to solar heating and renewable energy.

The solar collectors operate as both solar radiation absorbers and as a multifunctional facade-cladding material. They are not just an additional element on the building. The collectors help to meet the economic and sustainability criteria of the project.

The solar facade is made-up of stainless steel absorbers. The absorbers contain heat exchangers through which the heat transfer fluid circulates.

The absorber is composed of two stainless steel sheets, each 0.6 mm thick. Regularly-spaced square patterns are stamped on the sheets. The front and back sheets are seam welded on the periphery and spot welded between each dent providing form stability, even at pressure levels of 3 bars. The two sheets are assembled back to back with the peaks and troughs shifted against each other so the fluid can flow through the resulting voids. This principle ensures a uniform water flow. The heat transfer is particularly efficient as the fluid is in contact with nearly the full surface of the absorber sheet.

The selective coating has absorption coefficient (α) of 0.95 and an emission coefficient (ϵ) of 0.15. The coating on the absorbers withstands outdoor weather conditions without alteration. Solar panels covered with this selective coating can be installed without glass covers. Unlike conventional collectors, the solar radiance reaches the absorber surface without partial absorption or reflection by glass. This minimises the effect of the angle of inclination and azimuth. The position of the solar collectors has a relatively low influence on

its degree of efficiency, allowing great flexibility in building integration. Inclined planes with slight slopes, curved roofs or vertical solar walls on facades are all possible.

Tests and experience have shown that the absorber concept is outstandingly efficient at relatively low temperatures or in mild climates. Under these conditions, the installations give results equal or even superior to those of glazed collectors. Unlike glazed solar collectors, they do not overheat.

The north facade has been completed with stainless steel elements of the same geometry. The elements have the same appearance as those on the south side, but they are made from a single sheet of stainless steel and are not thermally active.



FIGURE 8: Partial view of a non-active facade.
The stainless steel elements are visible below the windows of the upper floor (left).

Building integration

The solar collectors are multifunctional. They gain energy from solar radiation as well as forming an excellent corrosion-resistant building element. The collectors withstand the impact of aggressive climates without sustaining any damage and they are fully recyclable. Panels are modular in length, so they fit the modular demands of the building. The panels weigh about 10 kg/m^2 , an important consideration for easy assembly.



FIGURE 9: Details of the interconnection of the stainless steel collectors and connection to the upper tube for the heat transfer fluid

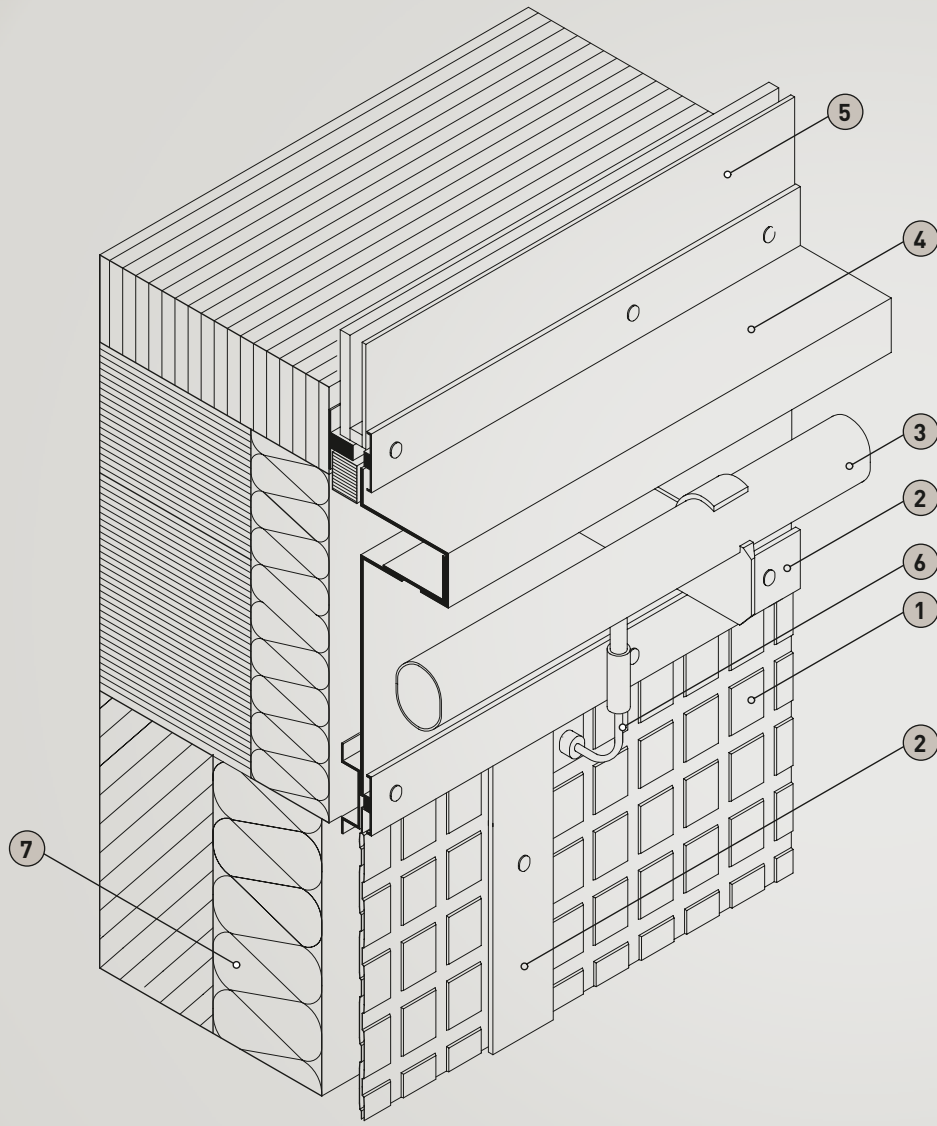
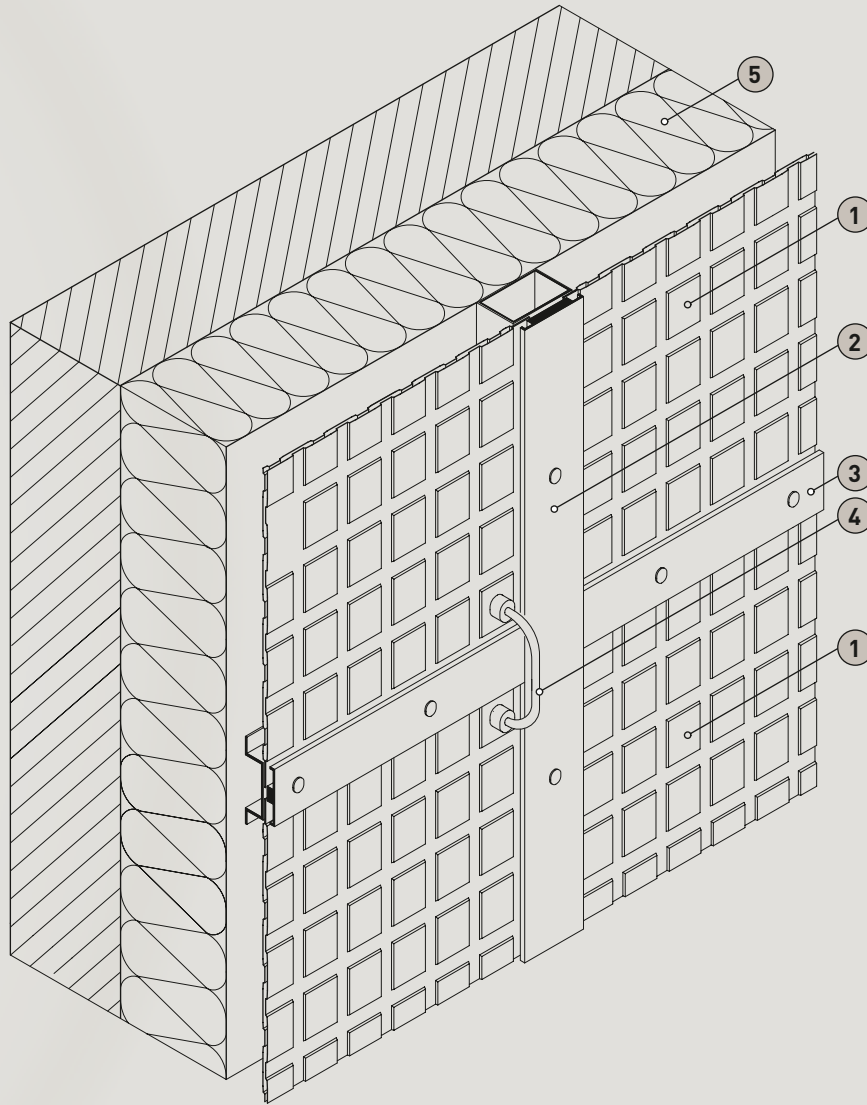

FIGURE 10: Detailed view of upper connection of solar collectors to the windows on the upper floor:

- 1 Stainless steel collector
- 2 Vertical and horizontal aluminium profiles
- 3 Upper tube for heat transfer fluid
- 4 Metal flashing sheet
- 5 Window of the upper floor
- 6 Tube connection
- 7 Thermal insulation.



Collector panels are fixed using aluminium profiles with EPDM¹ joints. The profiles are used to fix conventional metal cladding. Once mounted, the facade is watertight and durable.

FIGURE 11: Detailed view of joint of four solar collectors:
 1 Stainless steel solar collector
 2 Vertical aluminium profile
 3 Horizontal aluminium profiles
 4 Tube connection between lower and upper collector
 5 Heat insulation.

1 ethylene propylene diene monomer rubber



FIGURE 12: Close-up of the connection of the collectors to the upper tube for heat transfer fluid

FIGURE 13: Stainless steel collectors during mounting:

- 1 Bearing structure for collectors fixed on inner wall
- 2 Bearing structure and thermal insulation
- 3 Non-active collector panels mounted on bearing structure
- 4 Lower row of collector panels.



Sustainability of Materials and Operation

Materials used in the construction of the building have been selected according to the criteria of ecology, low energy content and economy. The main materials used in the building are:

- Timber for the load-bearing structure
- Concrete recycled from demolition material
- Stainless steel for the facades and solar energy gains
- Timber and metal for the window frames.

The selection of materials is a major component of the sustainable architectural design. It also influences the form and arrangement of the buildings. A green roof adds to their eco-friendly profile.

The water supply comes from two sources. Valuable and expensive drinking water is used only for the kitchen, showers and bathrooms. Grey water (used to clean vehicles, irrigate the site and for lavatory flushing) is pumped from nearby Lake Geneva. A system to pump water from the lake is already used to irrigate the neighbouring vineyards. Sealed surfaces are reduced to a minimum, allowing rainwater to seep away into the ground.

A combined heating system is used for low-temperature floor heating and hot water production. The solar facade, with an area of 590 m² facing south-east, provides about 40% of the annual heat requirements. The rest is provided through a 240 kW woodchip boiler which burns waste wood from highway maintenance. The heat protection incorporated into the building means that annual heat requirements are only 30 kWh/m².

The use of a domed roof-light and windows enable the use of daylight and natural ventilation in the offices and garages. This contributes further to the operation of the building in an energy-conscious way. Around 97% of energy consumed in the building is either gained or produced on site. A 190 m² photovoltaic array provides electricity that is used in the building.



FIGURE 14: The main construction materials are timber (load-bearing structure) and stainless steel (multifunctional facade panels)

Conclusion

The CeRN building is a good example of a modern, energy-efficient building concept. Ecological aspects are considered as well as energy and economic ones. The architectural integration into the neighbouring vineyards is exemplary.

The facades are multifunctional, offering both weather protection and energy gain. In order to achieve the optimum solar yield, the stainless steel solar absorbers used in this project are fully irrigated and have a selective coating that withstands ageing under outdoor conditions without alteration. They clearly fulfil the sustainability criteria specified in the brief, including durability, grey-energy content and recycling. Approximately 12 tons of stainless steel sheets were used to construct the building.

The components used in the project offer the optimum solution to meet aesthetic, functional and ecological criteria.

Energy Data

Heat protection office section

Facades	$U = 0.3 \text{ W}/(\text{m}^2\text{K})$
Roof	$U = 0.11 \text{ W}/(\text{m}^2\text{K})$

Energy demand

Floor heating office	24.1 kWh/(m ² a)	67.0%	150,600 kWh/a
Hot water	5.45 kWh/(m ² a)	15.6%	35,000 kWh/a
Electricity	6.28 kWh/(m ² a)	17.4%	39,100 kWh/a
Total office section	35.8 kWh/(m ² a)	100.0%	224,700 kWh/a
Total garages included			448,000 kWh/a

Energy production in place

Photovoltaic array	191 m ²		23,875 kWh _{el} /a
Thermal solar collectors	576 m ²		288,000 kWh _{th} /a
Waste wood			120,000 kWh _{th} /a
Total production in place			431,875 kWh/a

External energy

Floor heating and hot water	0 kWh/a
Electricity	16,000 kWh/a

Project Data

LOCATION	CeRN Bursins • Eri Mély, 1183 Bursins, Switzerland
CLIENT	État de Vaud, Service Immeuble, Patrimoine et Logistique • Ripone 10, 1001 Lausanne, Switzerland
ARCHITECT	Atelier niv-o, Ivo Frei • Rue du Simplon 4, 1001 Lausanne, Switzerland
ENGINEERS	Bureau d'études Keller-Burnier • ch. de Renolly, 1185 Lavigny, Switzerland
ENGINEERS	MAB-Ingénierie SA, études techniques en électricité Avenue de la Gottaz 32, 1110 Morges, Switzerland
SOLAR COLLECTORS	Energie Solaire SA • CP 353, Z.I. Ile Falcon, 3960 Sierre, Switzerland
TEXT	hwp – hullmann, willkommen & partner • Schillerstr. 45, 22767 Hamburg, Germany
PHOTOS AND DRAWINGS	Energie Solaire SA (Figure 1, 6, 7) atelier niv-o (Figure 2, 3, 4, 5, 8, 9, 12, 13, 14, 15) hwp (Figure 10, 11)

